

A

B

C

TOLERANCES-UNLESS OTHERWISE SPECIFIED

DIM.

&gt;120

120-30

30-6

6-0

.X

.XX

ANGLES ± °

TOLERANCES

±2

±0.15

±0.1

±0.05

±0.05

±0.05

## REVISIONS

REV	DESCRIPTION	DESIGNED	CHECKED	APPROVED	DATE
△					

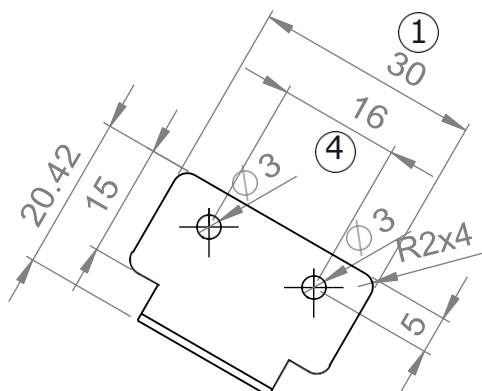
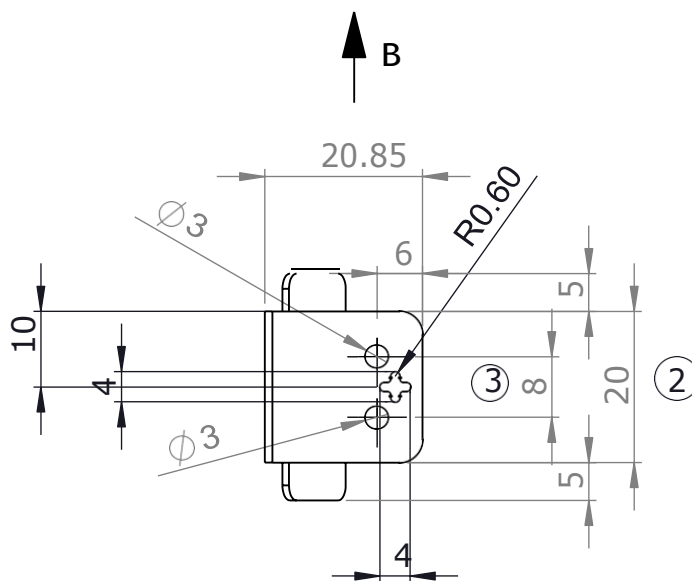
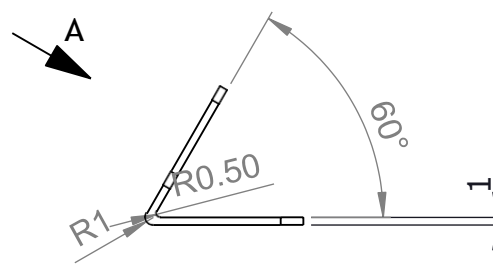
View A  
(Fixed to Host side)View B  
(Fixed to Scanner side)

MATERIAL : Stainless Steel, T=1.0 mm

MODEL : AS60

FINISHING :

PART NAME : 60-D MOUNTING PLATE

DO NOT SCALE  
THIS DRAWINGTHIRD ANGLE  
PROJECTIONUNIT  
m/m

SCALE 1/1

DRAWING NO.

SHT

NOTE:SUBMIT FINAL  
SAMPLES BEFORE  
STARTING MASS-  
PRODUCTION

DESIGNED

CHECKED

APPROVED

1/1

2014/10/2

PART NO.

AS60-60

EDI

△1.0