

A		B			C				
TOLERANCES-UNLESS OTHERWISE SPECIFIED		DIM.	>120	120-30	30-6	6-0	.X	.XX	
ANGLES ± °		TOLERANCES	±2	±0.15	±0.1	±0.05	±0.05	±0.05	

REVISIONS

REV	DESCRIPTION	DESIGNED	CHECKED	APPROVED	DATE
△					

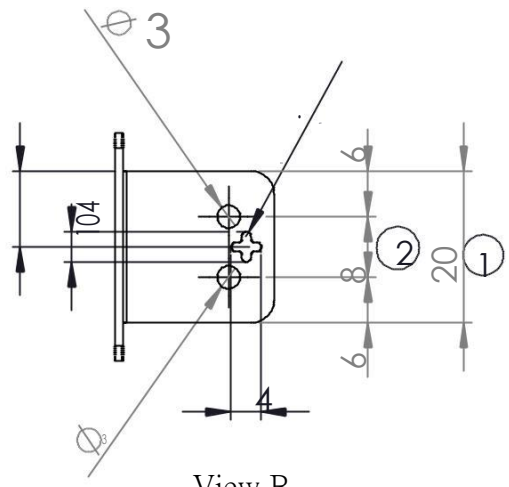
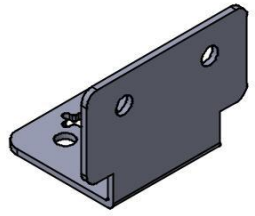

View B
(Fixed to Scanner side)

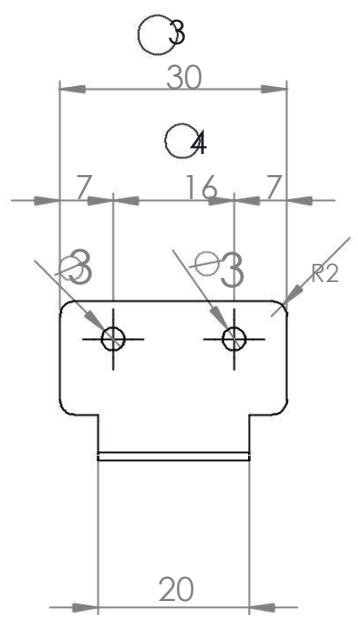

View A
(Fixed to Host side)

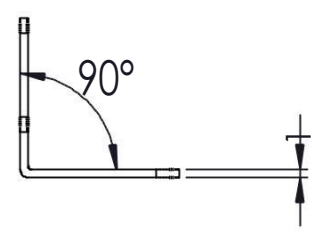
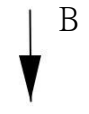
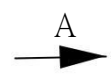

MATERIAL: Stainless Steel, T=1.0 mm			MODEL : AS60		
FINISHING :			PART NAME : 60-D MOUNTING PLATE		
DO NOT SCALE THIS DRAWING	THIRD ANGLE PROJECTION	UNIT m/m	SCALE 1/1	DRAWING NO.	SHT
	DESIGNED	CHECKED	APPROVED		1/1
NOTE: SUBMIT FINAL SAMPLES BEFORE STARTING MASS-PRODUCTION	2014/10/2			PARTNO.	EDI
				AS60-90	1.0